

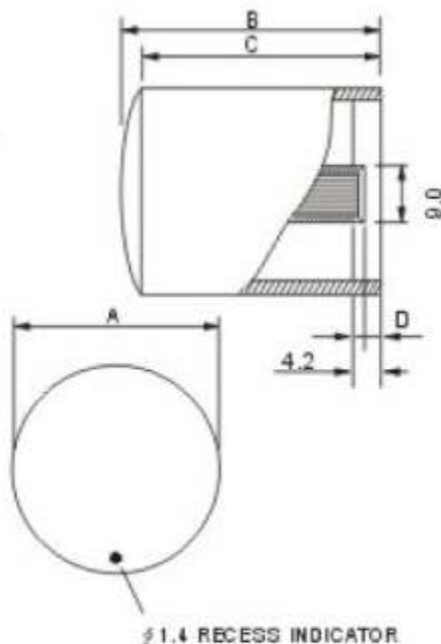

Description

- Material: ABS
- Finish: Matte texture on top
Hair line on the outside diameter
Indicator dot on the top
- Shaft hole: ϕ 6mm X 18 teeth



PART NO.	A	B	C	D
41028-1	15.0	17.6	17.0	3.2
41028-2	17.4	18.0	17.0	2.3
41028-3	19.5	17.1	15.7	3.5
41028-4	22.0	17.8	16.2	3.2
41028-5	30.2	17.8	15.7	3.0

ISS	ECN	SIGN	DATE	ISS	ECN	SIGN	DATE

NOTICE
ALL RIGHTS RESERVED.
UNAUTHORISED USE,
DISCLOSURE OR
REPRODUCTION IN
WHOLE OR IN PART IS
STRICTLY PROHIBITED.

© 2006



Durban Road, Bognor Regis
West Sussex, UK, PO22 9QT
Tel: +44 (0) 1243 860626
Fax: +44 (0) 1243 866626
email: sales@westside-supplies.co.uk
Web: www.westside-supplies.co.uk

STANDARD TOLERANCES
NO PLACE DEC. ± 0.5
1 PLACE DEC. ± 0.2
2 PLACE DEC. ± 0.1
ANGULAR $\pm 0.5^\circ$
UNLESS STATED OTHERWISE
SCALE: NTS

MATERIAL

FINISH

DRAWN	DATE	SIGN	DATE
RM	11/12/06		
TITLE Tuning Knobs			
DRAWING No 41028			A4